

SPS "Shallowflo" 100mm Push-in RWO (Variation Based on Truflo System)

Specification codes:

- SF100F (CI body, galvanised flat grate class D)
- SF100F2 (CI body, LM-6 flat grate & membrane ring)
- SF100D2 (CI body, LM-6 dome grate & membrane ring)

Suggested applications:

Applications where regular Truflo is too deep to fit, but not requiring normal "Truflo" flow rates

USE WITH CAUTION: Flow rates are only a fraction of those of regular Truflo

Hot-dipped galvanised mid-carbon steel flat grate, load class D per AS 3996-2006
FLOW RATE max 3 l/s

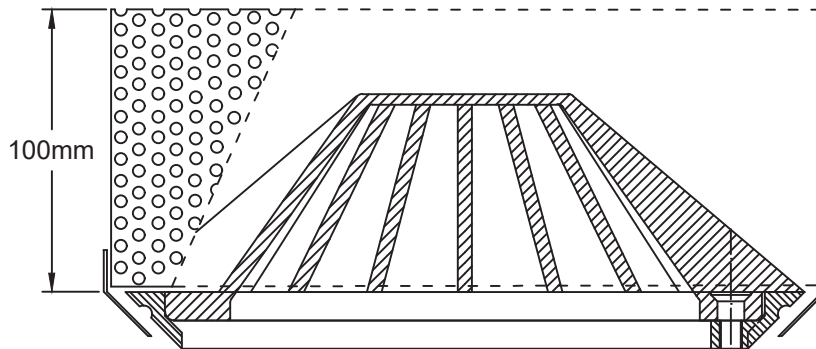
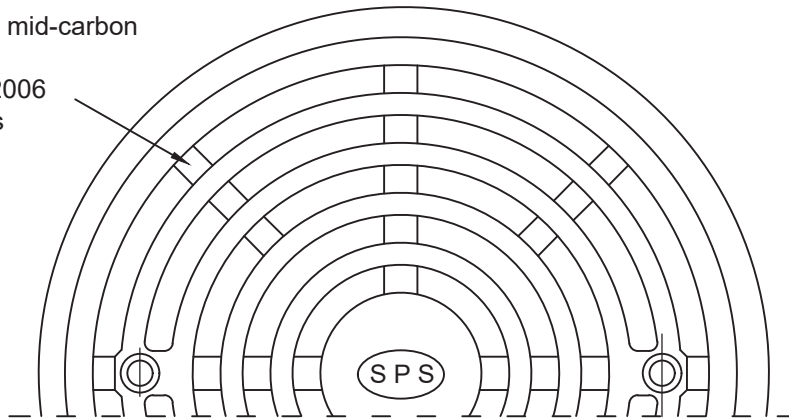

LM-6 dome grate and membrane ring, for roof slabs (note: optional gravel guard partially illustrated)
FLOW RATE MAX 3 l/s



LM-6 flat grate and membrane ring, for waterproofed slabs (eg roof decks & plant rooms).
FLOW RATE MAX 3 l/s

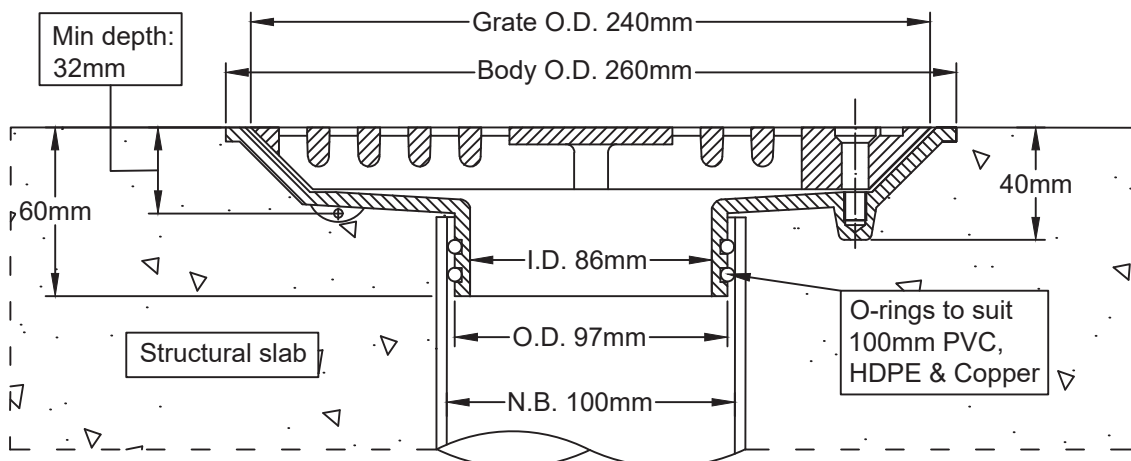

Metabronze Industries Ltd.

Office: 09 441 3824 Email: sales@metabronze.co.nz Website: metabronze.co.nz